

WE ARE COMMITTED TO SOLVING YOUR CHALLENGES

At Sandvik, we have established ourselves as market leaders in autogenous VSI crushing. In order to maintain our market lead, we have listened to our customers and put into practice many new solutions, to provide economy in use, reliability in operation and significant reductions in maintenance, combined with improved Health & Safety considerations.

MEETING YOUR EVER-CHANGING REQUIREMENTS

Working closely with our customers, and listening carefully to their needs, has led to many new solutions to improve business for crushing customers. The CV200 series is a good example. The six new models retain the features customers liked and build on them further, providing tangible benefits such as reduced power consumption, increased capacities, reduced maintenance costs and intervals.

WIDE RANGE OF APPLICATIONS

The VSI crusher is primarily a third or fourth stage crusher. Some, but by no means all, of the applications of this crusher are:

- Manufactured sand
- Premium shaped aggregates (concrete and road products)
- Recycling industry
- Industrial minerals industry
- Mining industry

The autogenous “rock on rock” crushing technique results in several major advantages: product gradation remains constant, even as rotor wear parts wear; contamination rates are extremely low, as no wear parts are used to directly crush the rock; unbeatable product shape (extremely low flake and elongation values).

CONCRETE ADVANTAGES

The CV200 series offers many real benefits over other existing autogenous VSI crushers:

- Reduced power consumption
- Further reduced operational cost per tonne
- Quick and easy replacement of wear parts and spare parts
- Consistent, easily-controlled product grading
- Reduced out-of-balance forces, resulting in longer bearing life (motors and crusher).

The result is a range of advanced, reliable, low-vibration machines that are unrivalled for their ability to increase productivity whilst minimizing downtime.



Reduced maintenance costs and intervals



Quality manufactured sand 0–5 mm and premium shaped aggregates 5–20 mm

BENEFIT YOUR BOTTOM LINE

ADVANCED ROTOR & WEAR PARTS

New patented advanced turbo tip plates effectively reduce high pressure laminated air found within the crushing chamber, leading to increased rotor life and reduced rotor maintenance.

New turbo cavity wear plates act similarly to the turbo tip plates, but also give up 30 % increased life during operation. Again further reducing maintenance downtime. These innovations combined with other crusher improvements result in an increase in crusher capacity with no more power consumption.

INCREASED THROUGHPUT WITH REDUCED POWER

Sandvik's patented Bi-Flow® system and high performance rotors, in conjunction with the

second generation wear parts, have resulted in even greater power reductions. Higher tonnage throughputs with reduced power have been proven in field tests of the 200 series.

Now up to 20 % of the maximum crusher throughput can be effectively handled through the Bi-Flow® system. This means a huge saving in electricity costs for the customer. However as electricity costs increase further, future cost savings will in reality be even greater. The CV200 series crushers are therefore better for the environment, with lower CO₂-emissions per tonne of product.

CLEAN, ENCLOSED OPERATIONAL CONTROLS AND TOOLS

Again from listening to our customers, we have provided a fully

enclosed hydraulic cabinet. This cabinet not only encloses the hydraulic system for quick and easy adjustment of the rotor throttle and drive belt tensioning, but also houses the semi-automatic greasing system and now also the maintenance tool kit.

The new cabinet now ensures that these vital components are housed away from dust and rain.

The inclusion of the tool kit, in a sturdy purpose made toolbox ensures instant accessibility when required for maintenance. The base of the cabinet is sealed to ensure that any accidental leaks of grease or oil are contained and do not pollute the environment.



Fully enclosed hydraulic cabinet keeps dust and rain away

REDUCING HEALTH AND SAFETY RISKS WITH LESS DOWNTIME

INTEGRATED FEED TUBE REPLACEMENT SYSTEM

This new patented system is a major breakthrough in VSI design. Historically the removal and fitting of the rotor feed tube has been a time consuming and costly operation. Either mobile lifting gear or expensive hydraulic options have been required. Both of these take time and money and require space around the crusher for their use.

With our integrated feed tube replacement system, the feed tube can now be replaced by one man through the crusher inspection door. This greatly reduces cost, space requirements and reduces health and safety risks.

RADIAL LOCK CAVITY RING

The new patented radial lock cavity ring is an important integral component. Whilst it is not a wear part, this component is vital for the effective operation of the crusher. The new design removes conventional fastener fittings and makes periodic replacement much easier, again reducing maintenance downtime and health and safety risks.

BI-FLOW® ACCELERATION SLIDES

The patented Bi-Flow® acceleration slides are an optional component used to solve the problem of effectively processing sticky, flaky

and elongated feed. These ensure that the Bi-Flow® system can be operated effectively, ensuring the lowest possible operational costs and greatest throughput.

UNIQUE KEY SAFETY INTERLOCK SYSTEM

At Sandvik, Health and Safety is an integral component of all design. This is why we supply as standard a timed unique trapped two key system, that ensures maintenance personnel safety combined with electrical isolation.

Also supplied and fitted as standard are a vibration detection switch and a pre-start alarm siren.



Faster and safer maintenance

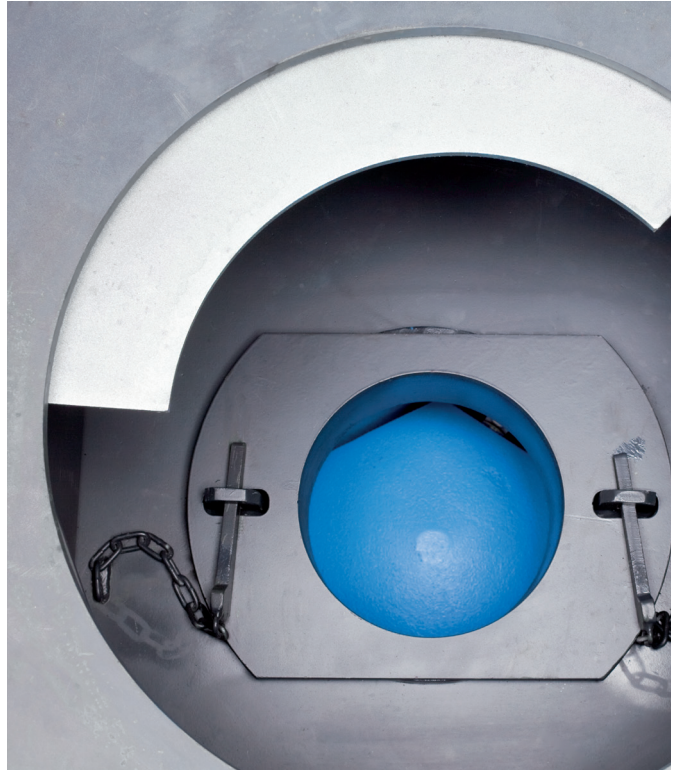

Integrated feed tube replacement system

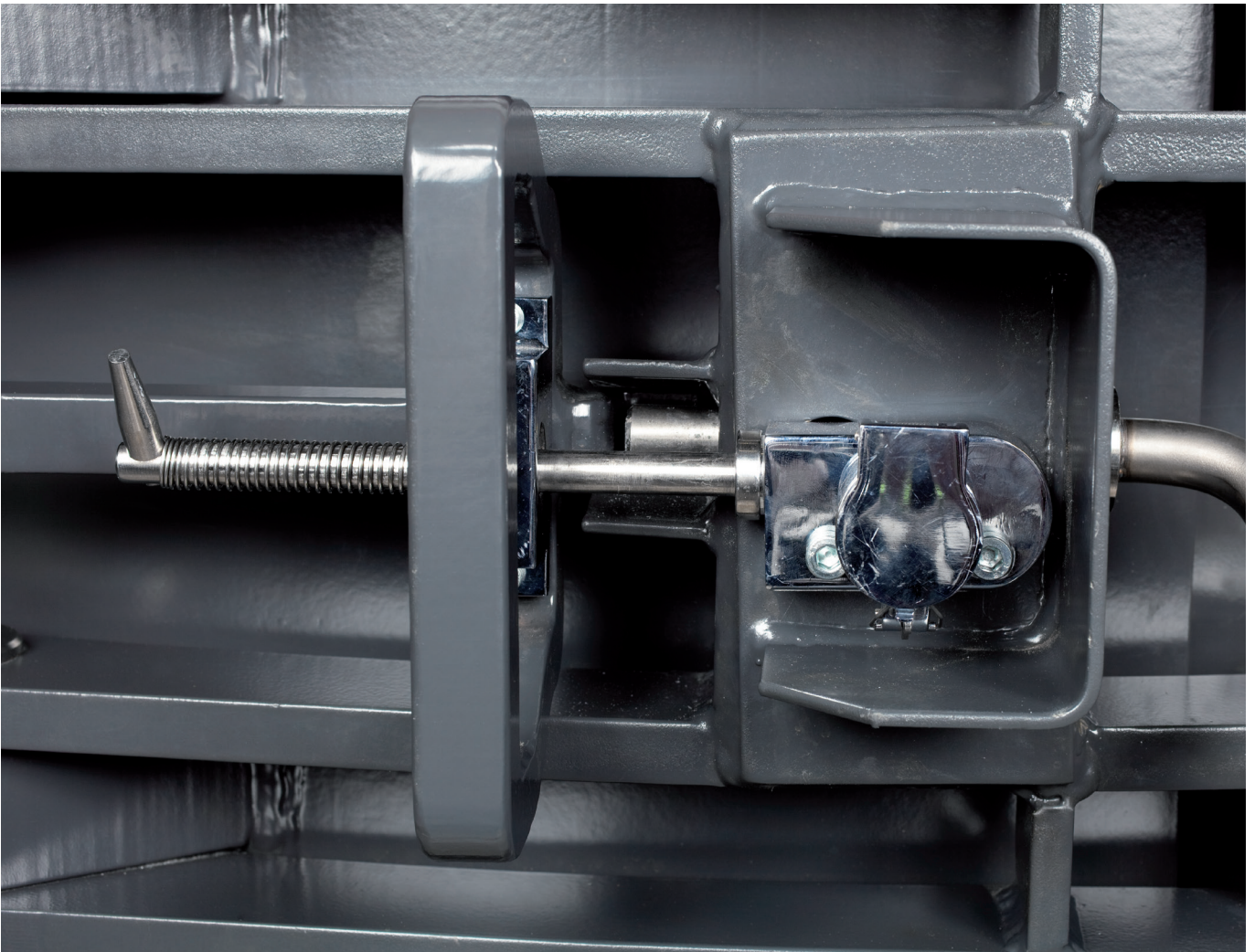

Unique key safety interlock system

PROVEN VALUES FOR BOTH NEW AND EXISTING CUSTOMERS

CUSTOMER CARE

We at Sandvik value both our new and existing customers. With this in mind, we have made it possible for existing customers to benefit from all of the new patented advantages of the CV200 series.

- The 2nd generation rotor wear parts (advanced turbo tip plates and turbo cavity wear plates), can all be fitted without modification to existing rotors.
- The integrated feed tube replacement system, can be retrofitted easily into any of the Sandvik CV100 series crushers. Retrofit kits, complete with instructions are available from your local Sandvik representative. Within only a few hours the crusher can be converted to allow existing customers the benefits of upgrading to all of the advantages of this new patented concept.
- The radial lock cavity ring can also be retrofitted when necessary. Again retrofit kits complete with fitting instructions are available.

The High Volume Feed Hopper system is another breakthrough in design. It ensures easy set up of the crusher to allow for differing ratios between rotor feed and Bi-Flow material. The main advantages are:

- Permits full loading of the crusher (maximize power draw)
- Allows the Bi-Flow® system to be utilized to the maximum extent. Permits easy control of the crusher, via the hydraulically operated rotor throttle system.

- Can be retrofitted into any earlier version of Sandvik VSI crushers. Increases crusher capacity.
- Increases crusher net production.

SUPPORT WHERE AND WHEN IT COUNTS

For most people, service is a matter of being available when problems occur. But we prefer seeing it as a matter of being proactive. Investment in, for instance, scheduled inspections and maintenance will help you protect your business from unexpected risks. Moreover, availability of essential parts and consumables, efficient and quick logistical processes, fully trained opera-

tors ... all these ensure trouble-free operations and maximize productivity. The patented "200" series VSI gives many real advantages over existing VSI crushers. Continuous research and development and customer feedback ensure Sandvik VSI crushers are the market leaders that others try and follow. From use in dam construction in China and Jordan, iron ore production in Kazakhstan, manufactured sand and aggregate production in the UK, India, Sweden, Latin America, Australia, industrial minerals in Germany, glass recycling in the UK and Australia, in fact all around the world in a variety of applications, Sandvik VSI crushers are In Action.

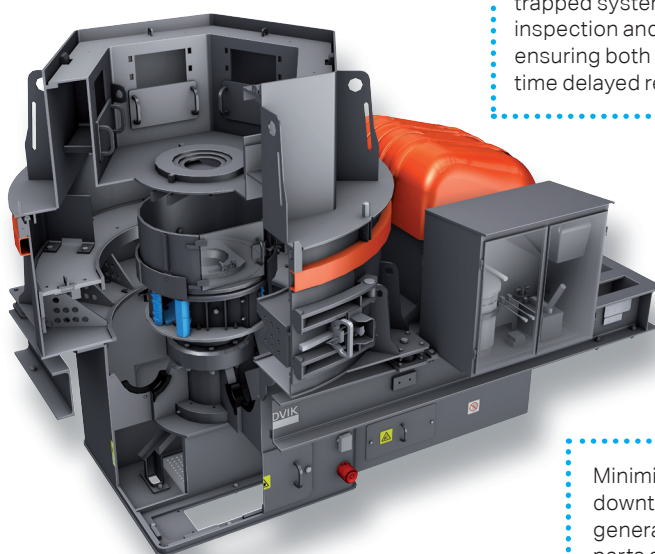

Safety in focus with unique two-key trapped system allowing for safe inspection and maintenance work, ensuring both electrical isolation and time delayed release of access keys.

Great reduction in power requirements and increased capacity through innovative and revolutionary design with both the rotor and crusher feed control systems.

Minimized maintenance downtime thanks to second generation of rotor and wear parts allowing quick and easy replacement, and through unique integrated feed tube replacement system permitting feed tube replacement via the crushing chamber inspection door.

MANUFACTURED SAND ON HAWAII

We all have our perception of Hawaii, most would think of golden sands and deep blue seas. Fortunately the golden sands and blue sea cannot be used in the construction, concrete and asphalt industries. That is why the forward thinking company, Hawaiian cement approached Sandvik.



The Halawa quarry was established in 1967 to fulfil the islands growing development needs. Hawaiian cement acquired the quarry in 1985 to further improve the quality of the islands infrastructure.

With global and local restrictions in the extraction and use of natural sands being implemented and the high cost of importing sand from British Columbia, Canada, some 2300 miles away, Hawaiian cement was looking to improve their environmental foot print, reduce operating costs and improve the quality in their products. Hawaiian cement needed an alternative solution. As a solution provider, Sandvik were

given the opportunity to introduce: "Sandvik Sand".

Hawaiian Cement chose Sandvik's CV229 VSI (autogenous) crusher. The CV229 is renowned for the very high quality of its finished products, high production rates, reduced power consumption and

ease of maintenance. Hawaiian cement are well on their way to achieving the goals. With the superior cubically shaped product produced by the Sandvik VSI crusher, packing densities of their sand has increased from 0.625 previous Hawaiian sand to 0.727 Sandvik manufactured sand.

The fineness modulus (FM) was decreased from an original figure of 3.36 to 2.76 with the manufactured sand produced in the Sandvik VSI crusher. These figures show the high quality of Hawaiian Cements new manufactured sand (less voids and improved shape) also the high level of performance of the Sandvik VSI crusher.

With the ever increasing demands for high quality aggregate products, tighter controls over specification with regard to elongation, flake and environmental issues, Sandvik have once again proved to be a reliable solution provider.

Comments from Hawaiian cement (Don Matsumura, general manager aggregate and maintenance and Jason Macy, vice president of operations). " Our aim is to eradicate the need for importing sand, and with the implementation of the Sandvik crusher we are well on the way to achieving this goal.

We have also decreased our environmental foot print, which is a fantastic achievement. We now have a crusher that is better for our beautiful environment, giving us better products for our customers and reducing our overall costs. What more could you ask for".

PACKING DENSITY TEST RESULTS HAWAIIAN SAND SAMPLES

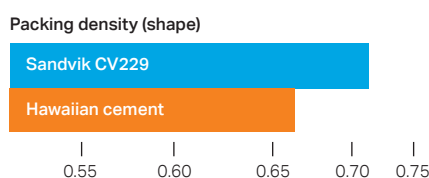

TECHNICAL SPECIFICATIONS

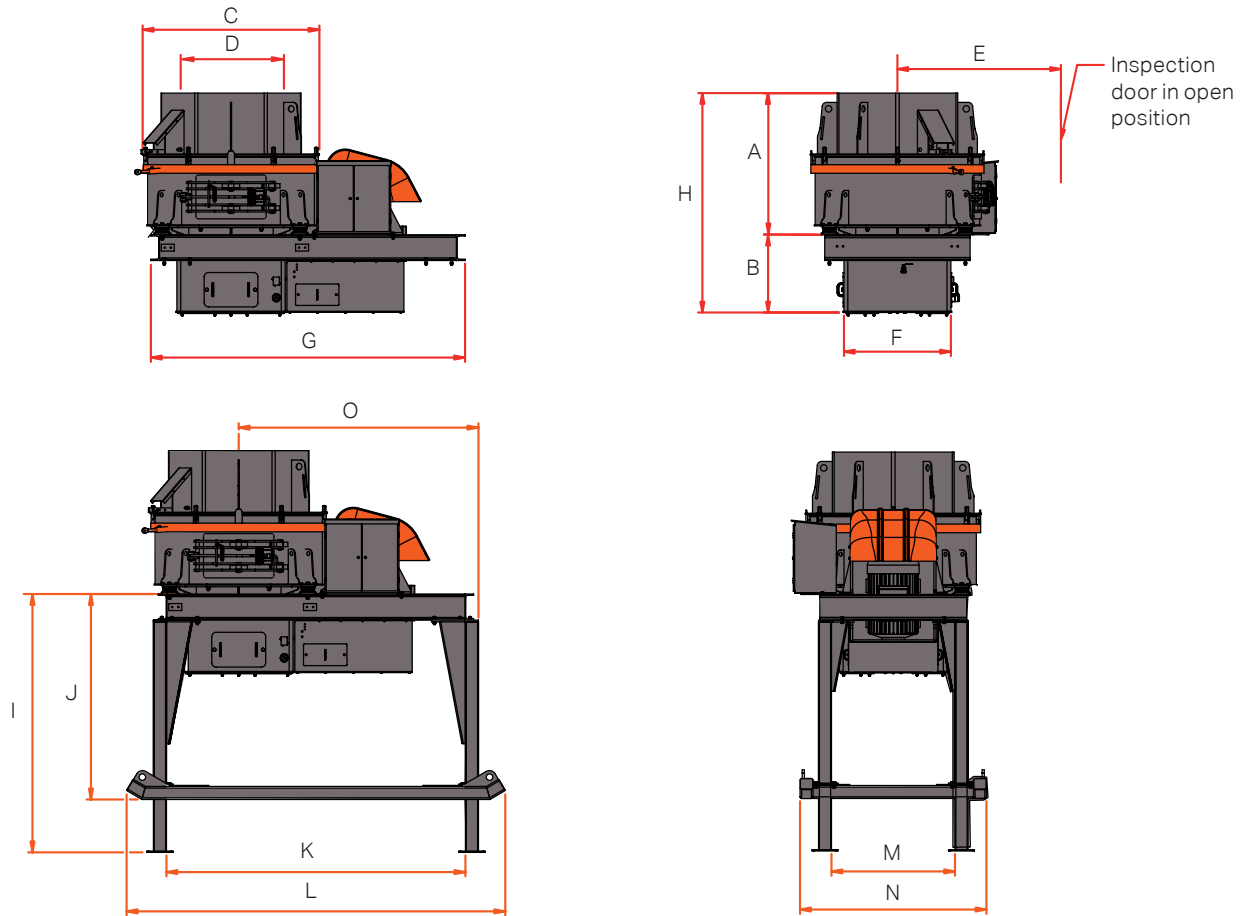

Dimensions mm (in)	CV215		CV216		CV217		CV218	
A	1 212	(47 3/4")	1 648	(64 7/8")	1 648	(64 7/8")	2 130	(83 7/8")
B	790	(31 1/8")	905	(35 5/8")	905	(35 5/8")	931	(36 5/8")
C	1 730	(68 1/8")	2 040	(80 3/8")	2 040	(80 3/8")	2 444	(96 1/4")
D across flats	902	(35 1/2")	1 016	(40)	1 016	(40)	1 216	(47 7/8")
E	1 840	(72 3/8")	1 912	(75 1/4")	1 912	(75 1/4")	2 090	(82 1/4")
F	1 070	(42 1/8")	1 250	(49 1/4")	1 250	(49 1/4")	1 420	(56)
G	3 166	(124 5/8")	3 626	(142 3/4")	3 626	(142 3/4")	3 750	(147 5/8")
H	2 002	(78 7/8")	2 553	(100 1/2")	2 553	(100 1/2")	3 061	(120 1/2")
I	2 231	(87 7/8")	2 970	(117)	2 970	(117)	3 076	(121 1/8")
J	2 362	(93)	2 362	(93)	2 362	(93)	2 480	(97 5/8")
K	2 978	(117 1/4")	3 438	(135 3/8")	3 438	(135 3/8")	3 562	(140 1/4")
L	4 355	(171 1/2")	4 352	(171 3/8")	4 352	(171 3/8")	4 355	(171 1/2")
M	1 170	(46)	1 430	(56 1/4")	1 430	(56 1/4")	1 480	(58 1/4")
N	2 158	(85)	2 158	(85)	2 158	(85)	2 228	(87 3/4")
O	2 427	(95 1/2")	2 757	(108 1/2")	2 757	(108 1/2")	2 806	(110 1/2")
Weight kg (lbs)	6 000	(13 228)	9 500	(20 944)	9 500	(20 944)	11 776	(25 963)
Max. feed size mm (in)	40	(1 5/8")	50	(2")	50	(2")	55	(2 3/16")
Capacity range MTPH (short tons)	10-50	(11-55)	51-121	(56-146)	122-192	(134-211)	193-250	(212-275)
Rotor rpm range (60 Hz speed)	1 568-2 101	(1 576-2 112)	1 381-1 982	(1 388-1 980)	1 391-1 973	(1 487-1 965)	1 401-1 677	(1 408-1 666)

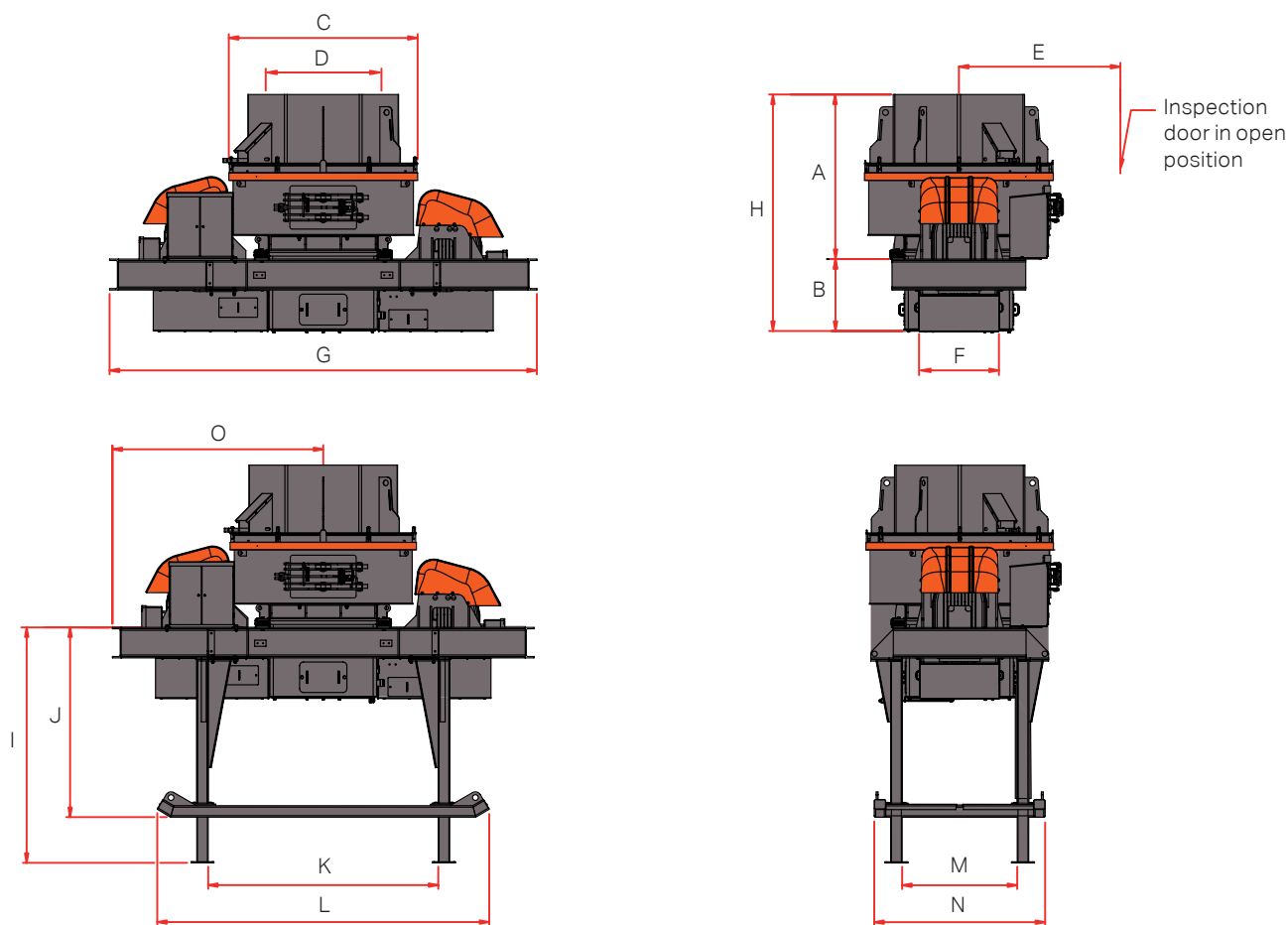

Dimensions mm (in)	CV228		CV229	
A	2 130	(83 7/8")	2 130	(83 7/8")
B	931	(36 5/8")	931	(36 5/8")
C	2 444	(96 1/4")	2 444	(96 1/4")
D across flats	1 216	(47 7/8")	1 216	(47 7/8")
E	2 090	(82 1/4")	2 090	(82 1/4")
F	1 420	(56)	1 420	(56)
G	5 500	(216 1/2")	5 500	(216 1/2")
H	3 061	(120 1/2")	3 061	(120 1/2")
I	3 090	(121 5/8")	3 090	(121 5/8")
J	2 480	(97 5/8")	2 480	(97 5/8")
K	3 018	(118 7/8")	3 018	(118 7/8")
L	4 355	(171 1/2")	4 355	(171 1/2")
M	1 500	(59)	1 500	(59)
N	2 228	(87 3/4")	2 228	(87 3/4")
O	2 750	(108 1/4")	2 750	(108 1/4")
Weight kg (lbs)	14 826	(32 686)	14 826	(32 686)
Max. feed size mm (in)	55	(2 3/16")	55	(2 3/16")
Capacity range MTPH (short tons)	251 – 444	(276 – 489)	445 – 600	(490 – 661)
Rotor rpm range (60 Hz speed)	1401 – 1677	(1408 – 1666)	1401 – 1677	(1408 – 1666)

