



Available with optional hanging screen system

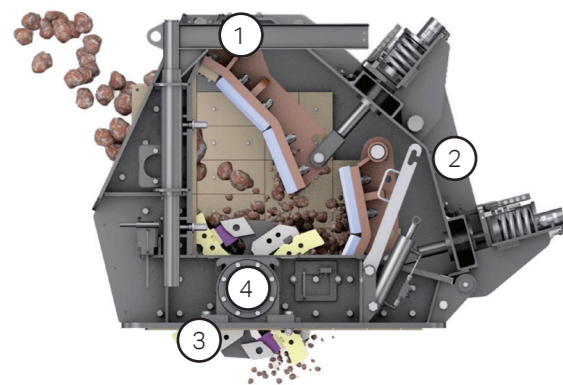

Diagram illustrates the curtain pivot shafts in lower position for secondary applications.

Featuring Sandvik's unique CI411 Prisec™ impact chamber (5 patents pending). The Prisec™ concept enables one base crusher to be configured as either a Primary or Secondary chamber whilst maintaining optimum crushing geometry.

Diagram illustrates the curtain pivot shafts in upper position for primary applications.

- 1 Lifting jib and blowbar cradle supplied as standard for quick and easy maintenance.
- 2 Heavy duty fully welded chamber enclosure to withstand the toughest of applications.



- 3 Heavy duty 4 bar rotor with interchangeable hammer configuration.
- 4 Heavy duty oversized spherical roller bearings for maximum strength and durability.

- 1 Chamber lined with interchangeable abrasion resistant tiles which can be turned for maximum usage.
- 2 Apron V block brake adjustment and overload system for maximum protection.

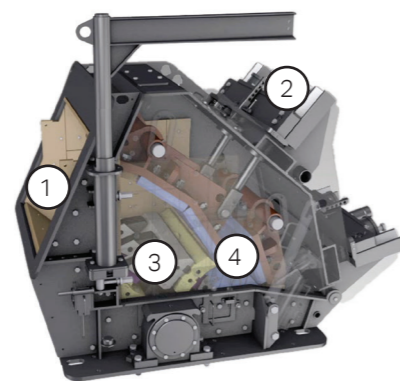

- 3 Wedge locking for simple blowbar retention.
- 4 2 Heavy duty aprons lined with abrasion resistant Sandvik liners.



TECHNICAL SPECIFICATIONS

KEY SPECIFICATIONS	DATA
Primary feeder	
Wear resistant lined feeder	910 mm x 2330 mm / 3' x 7' 8"
Pre screen	
Type	2 bearing, high amplitude screen 2 screening decks
Top deck size	1520 mm x 980 mm / 5' 0" x 3' 2 1/2"
Bottom deck mesh	1020 mm x 980 mm / 3' 4" x 3' 2 1/2"
Pre screen top deck media	40 mm / 1 1/2" punch plate
Pre screen bottom deck media	20 mm / 3/4" mesh
Underpan feeder size	830 mm x 2040 mm / 32 1/2" x 6' 8"

KEY SPECIFICATIONS	DATA
Impactor	Sandvik CI411 Prisec™ Impactor
Feed opening	992 mm x 670 mm / 39" x 26 1/2"
Hydraulic inlet opening	992 mm x 830 mm / 39" x 32 1/2"
2 aprons	Hydraulic assist
Maximum feed size	600 mm / 23 5/8"
Engine	CAT C9 / C9.3 Acert 261 kW / 350 hp
Fuel tank	660 litres / 174 USG
Hydraulic tank	660 litres / 174 USG

Note. All weights and dimensions are for standard units only

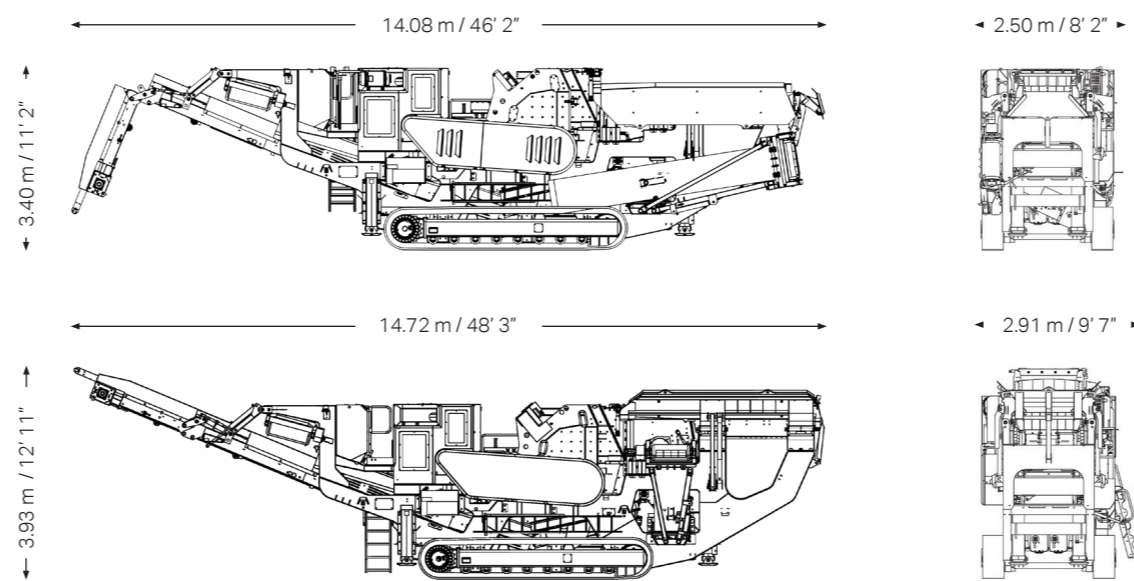

Standard weight 37,200 kg / 82,012 lbs

BS-327 ENG rev © Sandvik Construction 2016 SANDVIK is a registered trademark owned by Sandvik Intellectual Property AB in Sweden and other countries.



QI341 PRISEC™ IMPACTOR ENGINEERING IN MOTION



QI341 PRISEC™ IMPACT CRUSHER ENGINEERING IN MOTION

KEY SPECIFICATIONS	DATA
Equipment	Sandvik CI411 Prisec™ Impactor
Feed opening	992 mm x 670 mm / 39" x 26 1/2"
Maximum feed size	600 mm / 23 3/8"
Engine	C9 / C9.3 Acert 261 kW / 350 hp
Transport dimensions	14.08 m / 46' 2" (l) 2.50 m / 8' 2" (w) 3.40 m / 11' 2" (h)
Weight	37,200 kg / 82,012 lbs
Weight (with HS)	44,978 kg / 99,160 lbs

COMPACT IMPACT CRUSHING

The QI341 has been built utilising market leading Sandvik Impactor technology which has enabled the development of a fully mobile, compact impact crusher.

It features the Sandvik CI411 Prisec™ impact crusher, which has been designed to work either in a primary or secondary capacity providing the operator an unparalleled level of flexibility, productivity and control. Available also with an optional hanging screen system, this will provide customers an even greater return on investment through the ability to produce accurately sized products for immediate use.

The compact dimensions of the QI341 make it perfect for sites where space is limited, but where superb product shape and high levels of production are required.

FEATURES INCLUDE:

- Excellent reduction ratio across a broad spectrum
- Emissions compliant 261 kW / 350 hp engine for powerful cost efficient performance
- Overband magnet, pre screen and underpan feeder fitted as standard
- Choice of pre screen media which provides the flexibility to suit any application
- 50°C ambient temperature capability without the need for an oil change
- Direct drive through hydraulic wet clutch
- Designed for optimum fuel economy and low operating costs.

STANDARD FEATURES



Hydraulic raise and lower on the main conveyor

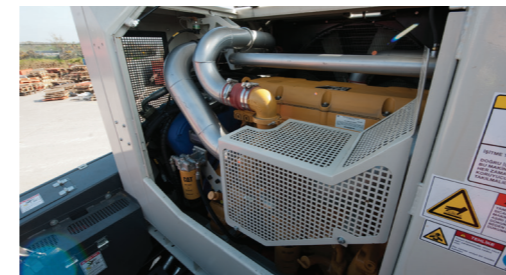

Easy access to the engine compartment



User friendly PLC control system with colour screen



Double deck vibrating pre screen



Vibrating primary feeder



Overband magnet



- 1 Main conveyor
- 1000 mm / 39 1/2" wide conveyor with a discharge height of 3762 mm / 12' 4"
 - Hydraulic raise / lower facility to give increased clearance for rebar discharge in recycling applications
 - Overband magnet removes rebar for recycling and demolition applications
 - Dust suppression complete with canvas covers fitted as standard
 - Highly efficient belt scraper

- 2 Power pack
- 261 kW / 350 hp emissions compliant engine
 - Direct drive through hydraulic wet clutch
 - Easy access to engine compartment for service and maintenance
 - Ground level drainage points (oil/diesel/cooling/engine oil)
 - Large capacity 660 litres / 174 USG diesel tank

- 3 Impactor box
- Sandvik CI411 - Patented design to work in either a primary or secondary application
 - Feed opening 992 x 670 mm / 39 x 26 1/2" 4 blow bar rotor - 1005 mm / 39 1/2" diameter
 - Ceramic blow bars fitted as standard
 - Variable speed of 573 rpm to 707 rpm
 - Tip speed range of 30 to 37 m/s / 98 to 121 ft/s to achieve a wide range of product gradations
 - Inlet opening can be raised to clear blockages from the radio remote

- 4 Pre screen
- Heavy duty double deck pre screen
 - Choice of media
 - 3 position by-pass chute for ultimate separation
 - Fitted with a pre screen to ensure maximum scalping capability to increase throughput and reduce wear cost

- 5 Hopper
- Reinforced hopper with hydraulically folding doors
 - Extensions available (optional)

- 14 Hanging screen system (optional)
- 4 x 1.5 m / 13' x 5' single deck screen for recirculation back to feed conveyor, or stockpiling through 90° rotation of oversize conveyor to produce two products
 - Hydraulic operation from recirculating to stockpiling position

- 13 Chassis
- Heavy duty fabricated chassis on tracked frame
 - Hydraulic legs for increased stability and servicing capabilities (optional)

- 12 Tracks
- 400 mm / 15 3/4" wide tracks driven by proportional umbilical control
 - Radio remote (optional)

- 11 Control system (other side of machine)
- New hydraulic and electric system for greater efficiency provides ultimate control
 - User friendly PLC control system with colour screen for full automated control

- 10 Cooling fan
- Hydraulically driven cooling fan with auto reverse to back flush dust from radiator

- 9 Steel pipework (other side of machine)
- Provides a safe and maintenance-free sealing solution, combined with better heat dissipation

- 8 Underpan feeder
- Fitted as standard for maximum belt protection and to reduce spillage

- 7 Natural fines conveyor (optional)
- Fitted for removal of fines
 - Belt width 650 mm / 25 1/2"
 - Discharge height 2630 mm / 8' 8"
 - Speed monitored to avoid blockages in the by pass chute