

DOOSAN

Crawler Excavators |
DX160/DX180LC-5 HT



Maximum power: 109/127 HP
Operating weight: 16.8/18.5 t
Max. bucket capacity: 0.59/0.76 m³





Engine

	DX160LC-5 HT	DX180LC-5 HT
Make / Model	PERKINS 1204F	
No. of cylinders	4	
Displacement	4.4 l	
Max. net power at 2000 RPM (SAE J1349)	81.6[109] kW[Hp]	94.9[127] kW[Hp]
Max. net torque at 1400 RPM (SAE J1349)	51 kgf.m	54 kgf.m

Weights

Operating weight with ROPS cab	16.8 t	18.5 t
--------------------------------	--------	--------

Performance

Bucket digging force (ISO 6015)	11.1 t	13.1 t
Arm digging force (ISO 6015)	6.0 t	9.3 t
Traction force (fast/slow)	12.5/20.5 t	
Ground pressure	0.37 kg/cm ²	0.44 kg/cm ²
Travel speed (fast/slow)	3.68/2.24 km/h	5.1/3.1 km/h
Travel motor shaft torque (fast/slow)	51.5/84.4 kgf.m	
Gradeability	70°	

Hydraulic system

Pump type	Swash plate, axial piston	
Main pump max. flow rate	2 × 114 l/min	2 × 152 l/min
Pilot pump max. flow rate	30 l/min	
Relief valve pressure - Normal/Pressure-up	330/350 kgf/cm ²	

Environmental

A-weighted emission sound pressure level at the operator's position, LpAd (ISO 6396:2008)	70 dB(A)	68 dB(A)
A-weighted sound power level, LwAd (2000/14/EC)	99 dB(A)	100 dB(A)

High track advantage



Reinforced track frame

- The track frame reinforced with additional plate gives customers the confidence to travel in rough conditions
- Strong under cover to protect major components from any obstacles like wood trunks, rocks, etc.
- Reinforced track-frame to prevent any possible deformation while working in tough area



Higher ground clearance

The extra ground clearance allows the crawler excavator to move over tree-trunks and travel on un-paved roads.

Strong traction system with reinforced upper rollers

The reinforced upper rollers make our traveling system even more durable. The result: longer traveling time and distance, especially in harsher environments.

In addition, the 18-ton class travel device on the DX160LC-5, and the reinforced breaking performance on the DX180LC-5, provide more traction force for pulling heavy objects or piled logs.

Dimensions

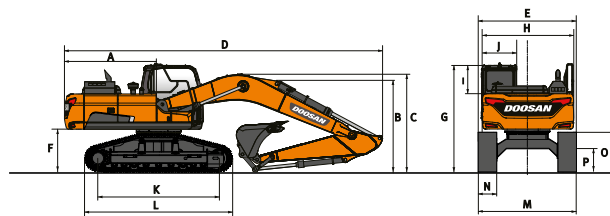

	DX160LC-5 HT		DX180LC-5 HT	
	4600		5200	
Boom - mm	2500	3000	2600	3100
Arm - mm	2500	3000	2600	3100
Bucket - m ³	0.51	0.45	0.70	0.57
A	mm	2205	2205	2530
B	mm	3020	2680	2765
C	mm	3200	2830	2865
D	mm	7720	7650	8720
E	mm	3000	3000	2900
F	mm	1175	1175	1195
G	mm	3065	3065	3080
H	mm	2540	2540	2540
I	mm	840	840	840
J	mm	1010	1010	1010
K	mm	3180	3180	3180
L	mm	3925	3925	3925
M	mm	2800	2800	2900
N	mm	600	600	700
O	mm	946	946	946
P	mm	615	615	615

Working range

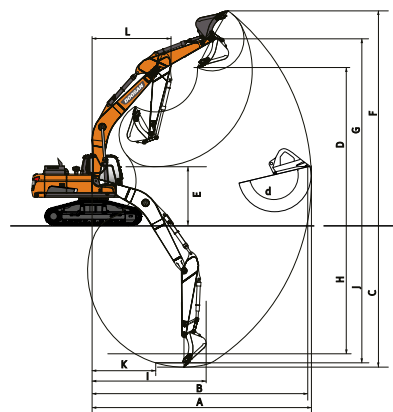

	DX160LC-5 HT		DX180LC-5 HT	
	4600		5200	
Boom - mm	2500	3000	2600	3100
Arm - mm	2500	3000	2600	3100
Bucket - m ³	0.51	0.45	0.70	0.57
A	mm	8285	8665	9190
B	mm	8080	8475	8985
C	mm	5355	5850	5955
D	mm	6605	6720	6655
E	mm	2765	2005	2535
F	mm	8940	9025	9325
G	mm	7815	7940	8075
H	mm	4210	4405	4830
I	mm	5605	5970	6165
J	mm	5115	5610	5745
K	mm	1915	1825	2435
L	mm	2380	2625	3210
d	mm	174	174	176

DOOSAN